

WS Series Electric Pallet Truck With Lithium Battery Specification

		HANGCHA GROUP CO.,LTD.					
		Model	CBD18-WS-5E	CBD15-WS-6SL	CBD15-WS	CBD20-WS	
Characteristics	1.1 Capacity	kg	2000	1500	1500	2000	
	1.2 Load center	mm	600	600	600	600	
	1.3 Overall fork width	mm	550/685	550/685	520/550/685	550/685	
	1.4 Fork length	mm	1150/1220	1150/1220	1150/1220	1150/1220	
	1.5 Overall length	mm	1552/1622	1552/1622	1552/1622	1552/1622	
	1.6 Overall height of fork	mm	82±2	65±2	82±2	82±2	
	1.7 Max.height of fork	mm	197	165	197	197	
	1.8 Overall height (with tiller)	mm	1276	1250	1276	1276	
	1.9 Rear body width	mm	550/685	550/685	520/550/685	550/685	
	1.10 Minimum turning radius	mm	1353/1426	1353/1426	1353/1426	1353/1426	
Performance	2.1 Max.Traveling speed	laden	km/h	4	4	4	4
		unladen	km/h	5	5	5	5
	2.2 Gradeability	laden	%	6	6	6	6
		unladen	%	20	20	20	20
2.3 Traveling	kw	DC 0.75 Brushless	DC 0.75 Brushless	DC 0.75 Brushless	DC 1.0 Brushless		
2.4 Lifting	kw	Hydraulic	DC 0.8	DC 0.8	DC 0.8		
Battery	4.1 Voltage	v	48	48	48	48	
	4.2 Capacity/type	Ah	10 Ah Lithium	10 Ah Lithium	10 Ah Lithium	10 Ah Lithium	
Brake type	5.1 Travel brake		Regenerate	Regenerate	Regenerate	Regenerate	
	5.2 Brake		Electromagnetic	Electromagnetic	Electromagnetic	Electromagnetic	
Controller	6.1 Controller		B1503	B1503	B1503	B1503	

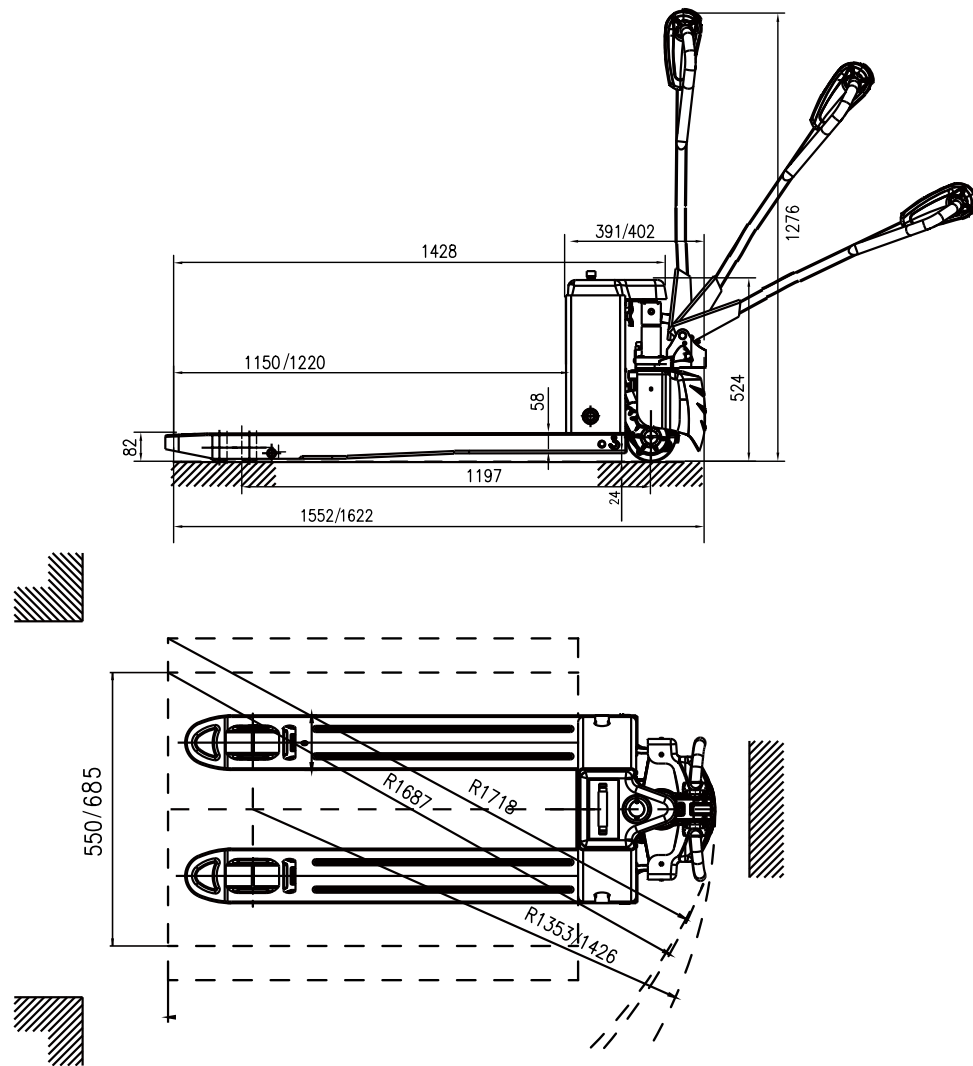

ZHEJIANG HANGCHA IMP. & EXP. CO., LTD.

Factory site: 666 Xiangfu Road,
Hangzhou, Zhejiang, China (311305)

Tel: +86-571-88926735 88926755
Fax: +86-571-88926789 88132890

sales@hcforklift.com
www.hcforklift.com



Follow us on
Facebook



Follow us on
YouTube



Follow us on
WeChat



ISO14001
ISO14001:2015



ISO9001
ISO9001:2015



HANGCHA trucks conform
to the European Safety
Requirements.

HANGCHA GROUP CO., LTD. reserves the right to make any changes without notice concerning colors, equipment, or specifications detailed in this brochure, or to discontinue individual models. The colors of trucks, delivered may differ slightly from those in brochures.

2019 VERSION / COPYRIGHT 2019/12



WS Series Electric Pallet Truck With Lithium Battery

with capacities of 1,500/1,800/2,000kg

The World of Hangcha
SINCE 1956



PERFORMANCE



UNLADEN 5Km/h

LADEN 4Km/h Full Electric / 3.5Km/h Semi-Electric

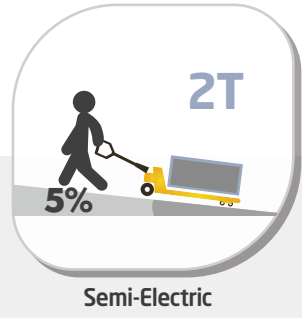
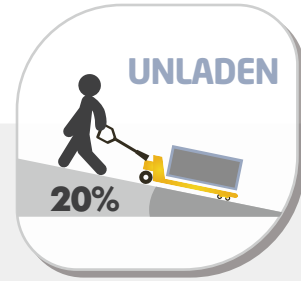

Gradeability

SMART FUNCTION

SMART FUNCTION 01

Turtle Speed
Horn Remains Pressed & Forward 2 times

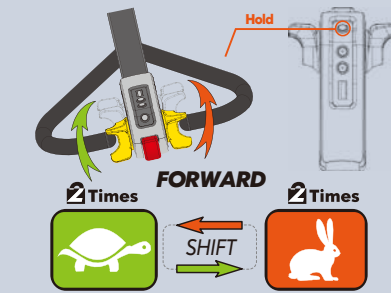

SMART FUNCTION 02

Up-Right Drive
Reverse Button & Forward Throttle Remain Pressed, Power On

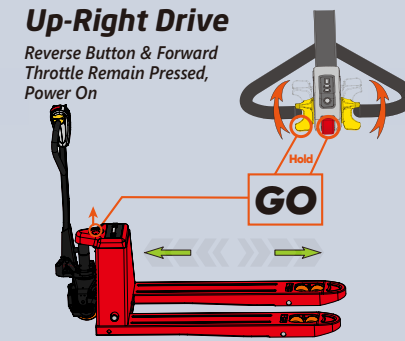

SMART FUNCTION 03

Engineering Mode (Brake Release)
Horn Remains Pressed, Power On

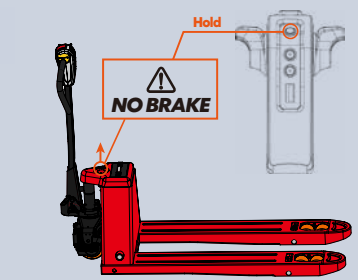

- ⚠ In up-right drive mode, vehicle will move when handle is operated at any position. Please avoid misoperation.
- ⚠ Brake release mode is only for emergencies, not allowed for vehicle with normal conditions.

CHARACTERISTICS

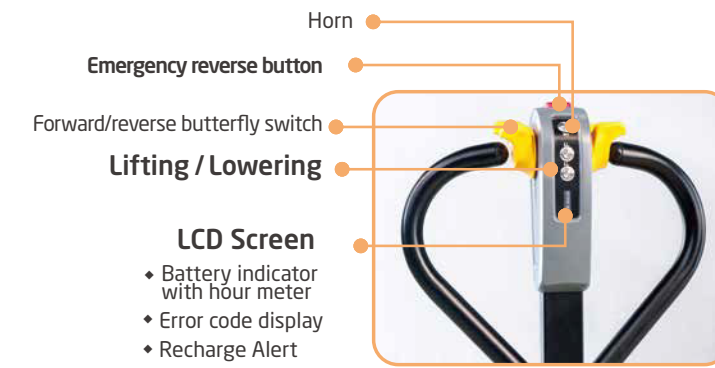

- LCD Screen
- Battery indicator with hour meter
 - Error code display
 - Recharge Alert

Multi-function Handle (Full Electric)

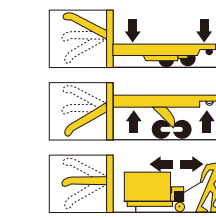

Multi-function Ergonomic Handle (Semi-electric)



Protection cover



Electric Lifting/Lowering



Lithium battery pack



Battery Protection Stopper

OPTIONS



Tandem/Single PU wheel



15Ah Lithium Battery



Fast Charger 2hrs



Intelligent Control Key

BUILT TO WORK 24 HOURS

SMART SIZE ALMOST SAME

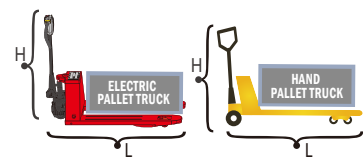

LIGHT WEIGHT

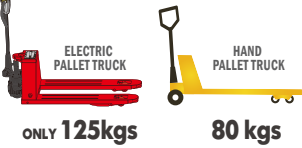

EFFICIENCY

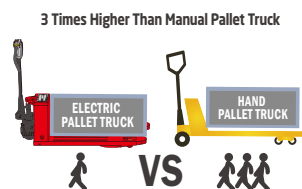

EASY MAINTENANCE

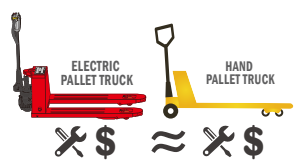

LIFETIME

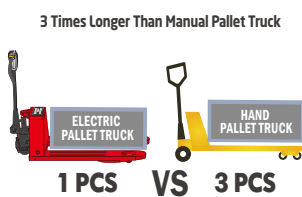

PAY A LITTLE MORE SAVE MUCH MORE

MAINTENANCE SO EASY

5 YEAR WARRANTY CHASSIS



Brushless drive motor, maintenance free

Lithium-ion Lithium battery maintenance free

Recharge Alert

Error code display

6s Replace Battery

60s Replace Drive Wheel

max