



ZHEJIANG HANGCHA IMP. & EXP. CO., LTD.

Factory site: 666 Xiangfu Road,
Hangzhou, Zhejiang, China (311305)

Tel: +86-571-88926735 88926755
Fax: +86-571-88926789 88132890

sales@hcforklift.com
www.hcforklift.com



Follow us on
Facebook



Follow us on
YouTube



Follow us on
WeChat



Download "Hangcha
Forklift" App



ISO14001
ISO14001:2015



ISO9001
ISO9001:2015



HANGCHA trucks conform
to the European Safety
Requirements.

2023 VERSION 2/COPYRIGHT 2023/04

HANGCHA GROUP CO., LTD. reserves the right to make any changes without notice concerning colors, equipment, or specifications detailed in this brochure, or to discontinue individual models. The colors of trucks, delivered may differ slightly from those in brochures.



**A Series High-lift
Order Picker**
with capacities of 1,200kg



The World of Hangcha
SINCE 1956



LET THE LIUM POWER BE KE



INNOVATIVE SOLUTIONS NEW POWER NOW

Innovative, reliable lithium-ion technology (Lithium Iron-Phosphate), which are developed jointly by HANGCHA and CATL. Battery cells and modules are from CATL, with reliable quality, exclusively for HANGCHA.

- / We use square lithium iron phosphate batteries and modules used in large quantities by commercial vehicles in mature economies.
- / The module uses an aluminum alloy frame which is sturdy, lightweight and with excellent heat dissipation.
- / Safe and effective: Charging efficiency as high as 98%, thermal runaway temperature 600 °C or above.
- / Adapted to low temperatures: Comes standard with an electrical heating feature, ensuring normal operation in low temperatures.
- / Quick charging: 2 hours full charge, economic use of each break.
- / Long-working: 4000 charging cycles, capacity retention greater than 80%.
- / Maintenance-free: Battery does not require manual maintenance.
- / Green and clean: Pollution-free, zero emissions.

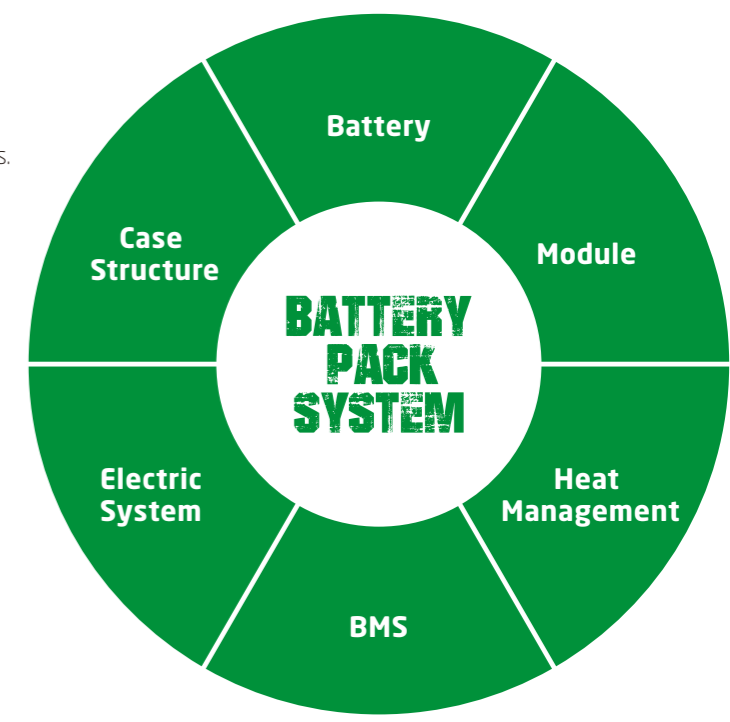

Li-Ion
2 hours
100%

Lead-acid batteries
8-10 hours 100%

Rapid charging and opportunity charging ensure continuous availability of vehicles.

Li-Ion powered forklifts are always available. They allow for fast full charging or boost charging (100 % charge in 2 hours). They are maintenance free and do not require a battery change when used for multi-shift operations.

Li-Ion Battery Pack specification

Type		CJD12-AC4-HI*	CJD12-AC4-HKI*
Li-Ion battery	V/Ah	51.52/500	51.52/500
Titans charger		SLC-48200	SLC-48200

Note: * CE model



HANGCHA provides Li-Ion battery (LiFePO4) with 5 years or 10000 hours warranty.





A Series High-lift Order Picker

The A Series high-lift order picker, a high-end warehouse equipment, provides a comprehensive safety protection system, excellent ergonomics design and advanced control system. Being reliable and stable, comfortable and safe, and along with excellent performance, it is a perfect option for cargo picking in stereoscopic warehouse that is 5m to 10m high.

HIGH PERFORMANCE TO ORDER

Comfort

- / Standard equipped with height sensors, and buffer function in mast switching, lifting and lowering, it provides more comfort to the operators.
- / The standard LORD steering gear with torque feedback system improves operation safety and comfort.
- / The lifting and lowering speed of the operating platform and fork can be adjusted steplessly, to achieve accurate control.
- / The standard equipped CURTIS multi-function instrument has many functions such as mode selection, wheel position display, etc., and can clearly show various information of the vehicle.





Reliability

- / The mast is made of high-strength steel plate, which is sturdy and reliable.
- / All wires and cables are reliably protected, greatly improving the reliability of the electrical system.
- / Important components adopted such as switches, connectors, instruments, etc. are foreign high-quality products, with excellent performance and reliable quality.

Safety

- / The FREE acceleration lever with an inductive switch is equipped as standard to prevent accidental contacts during operation.
- / Equipped with a tilt switch sensor as standard, operation and control safety is improved.
- / The left and right guard rails are equipped with safety detection switches.
- / With 10 times safety factor, the mast chain is also equipped with a chain safety switch.
- / The driving speed is related to the lifting height. The higher the lifting height, the lower the driving speed and the smaller the acceleration.
- / The function of proportional speed reduction in corners is equipped as standard to ensure smooth and safe turning of the vehicle.
- / With emergency lowering function, it can be operated separately on the operating platform and the rear of the vehicle.

High Performance

- / The maximum driving speed at full load is up to 10km/h, which greatly improves the work efficiency.
- / The Germany ZF reduction gearbox, Schabmueller AC drive and steering motor, contribute to a better performance and greater stability.
- / AC hydraulic lifting system offers high efficiency and free maintenance.
- / The advanced CURTIS AC control system provides precise, smooth and efficient control.
- / The CANBUS structure engages faster and more reliable communication.

Maintenance

- / The AC motor has no carbon brush and is maintenance-free, which greatly saves the cost of use.
- / The integrated power display, timing and fault self-diagnosis meter is convenient for maintenance.
- / The rear hood can be easily disassembled for easy maintenance of hydraulic unit, electronic control, motor and other parts.

Standard Specification

- / ZF drive unit assembly
- / LORD steering gear
- / CURTIS AC motor controller
- / Free acceleration lever (with inductive switch)
- / Automatic speed reduction in corners
- / CURTIS multi-function instrument
- / Chain switch
- / Guard rail switch
- / Reflective mirror
- / LED top light
- / LED sidelight
- / Emergency power off switch
- / Police light
- / Height sensor
- / Safety pedal
- / Tilt switch
- / Left and right guard rail
- / Folder
- / Back cushion
- / Cup holder
- / Electrostatic belt
- / Electromagnetic brake
- / Supplementary lift (only for CJD12-AC1-H)
- / Full-length safety belt + single-hook shock cord (only for CJD12-AC1-HK)
- / Mounted fork (only for CJD12-AC1-H)
- / Welded fork (only for CJD12-AC1-HK)

Options

- / Side roller
- / Blue light
- / Head Lamp
- / Masts available in various heights
- / Battery trolley



Supplementary lift on operator platform. Pallet can be raised to most convenient working level for picking



Rail guidance rollers (Opt.) can be fitted to the truck for VNA working



Control and display panel integrated are perfectly in the drivers field of view



Standard LCD display informs the driver about all necessary informations



Simultaneous driving/lifting/lowering, simple and ergonomic controls allow precise operation reducing driver fatigue and increasing throughput

A Series High-lift Order Picker Specification

Distinguishing mark	HANGCHA GROUP CO.,LTD.			
	1.1	Manufacturer		
1.2	Model	CJD12-AC4-H*	CJD12-AC4-HK**	
1.3	Drive:electric (battery or mains),diesel,petrol,fuel gas	Electric	Electric	
1.4	Operator type:hand,pedestrian,standing,seated,order-picker	Order picker	Order picker	
1.5	Rated capacity/rated load	Q(t)	1.2	
1.6	Load centre distance	c(mm)	400	
1.8	Load distance, centre of drive axle to fork	x(mm)	307	
1.9	Wheelbase	y(mm)	1566	
Weight	2.1	Service weight	kg	3960
Tyres, chassis	3.1	Tyres: solid rubber, superelastic, pneumatic, polyurethane	PU	PU
	3.2	Tyre size, front	Ø343×140	Ø343×140
	3.3	Tyre size, rear	Ø150×100	Ø150×100
	3.5	Wheels, number front/rear (* = driven wheels)	1x/4	1x/4
	3.7	Tread,rear	b11(mm)	856
Dimensions	4.2	Height,mast lowered	h1(mm)	2465
	4.4	Lift	h3(mm)	5000
	4.5	Height, mast extended	h4(mm)	7465
	4.7	Height of overhead guard (cabin)	h6(mm)	2300
	4.8	Standing height	h7(mm)	266
	4.11	Supplementary lift	h9(mm)	800
	4.15	Height,lowered	h13(mm)	75
	4.19	Overall length	l1(mm)	3400
	4.20	Length to face of forks	l2(mm)	2200
	4.21	Overall width	b1/b2(mm)	1000/1000
	4.22	Fork dimensions DIN ISO 2331	s/e/l(mm)	55/122/1200
	4.25	Distance between fork-arms	b5(mm)	540
	4.27	Width over guide rollers	b6(mm)	1200
	4.31	Ground clearance,laden,below mast	m1(mm)	50
	4.34.1	Aisle width for pallets 1000 × 1200 crossways	Ast(mm)	3535
	4.34.2	Aisle width for pallets 800 × 1200 lengthways	Ast(mm)	3656
	4.35	Turning radius	Wa(mm)	1812
Performance Data	5.1	Travel speed,laden/unladen	km/h	10/10
	5.2	Lift speed,laden/unladen	m/s	0.371/0.411
	5.3	Lowering speed,lade/unladen	m/s	0.486/0.448
	5.7	Gradeability,laden/unladen	%	10/10
	5.10	Service brake		Electromagnetic
Electric engine	6.1	Drive motor rating S2 60 min	kw	6.4
	6.2	Lift motor rating at S3 15 %	kw	12.8
	6.4	Battery voltage/nominal capacity K5	V/Ah	48/620
	6.5	Battery weight	kg	950
Addition data	10.7	Sound pressure level at the driver's seat	dB(A)	69

Note : * Without auxiliary lift
★ CE model

Mast Specification

Type	Model	Lift h3 (mm)	Lowered overall height h1 (mm)	Free lift h2 (mm)	Extended mast height h4 (mm)	Overall lift height h3+h4 (mm)	Order picking height h1s (mm)
Triplex DZ	N4500	4500	2315	15	6800	5300	6360
	N4750	4750	2385	85	7050	5500	6610
	N5000	5000	2465	165	7300	5800	6860
	N5500	5500	2630	330	7800	6300	7360
	N6000	6000	2800	500	8300	6800	7860
	N6500	6500	2965	665	8800	7300	8360
	N7000	7000	3130	830	9300	7800	8860
	N7500	7500	3345	1045	9800	8300	9360
	N8000	8000	3515	1215	10300	8800	9860
	N8300	8300	3615	1315	10600	9100	10160
	N8500	8500	3730	1430	10800	9300	10360
	N9000	9000	3955	1655	11300	9800	10860
N9250	9250	4040	1740	11550	10050	11110	
N9500	9500	4125	1825	11800	10300	11360	

RATED CAPACITIES AND LOAD CENTRES GRAPH

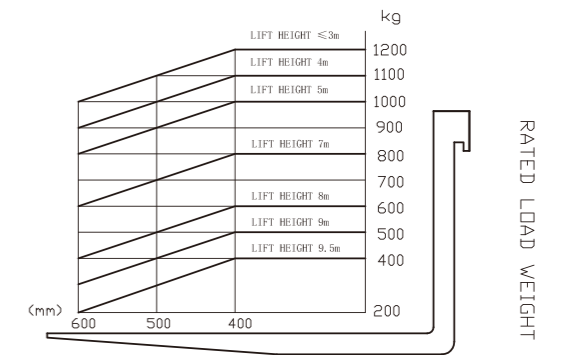

LOAD CENTRE POSITION

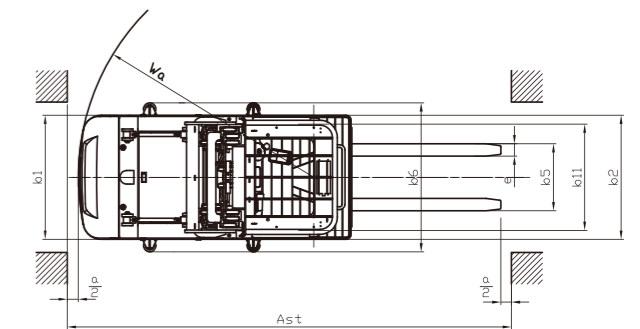
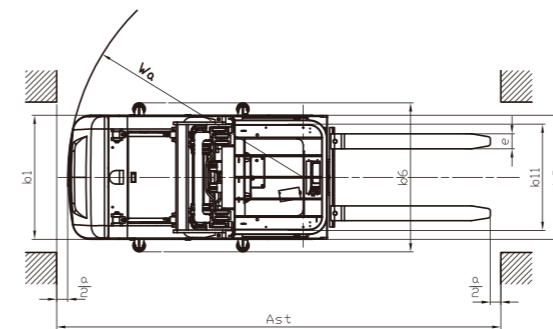
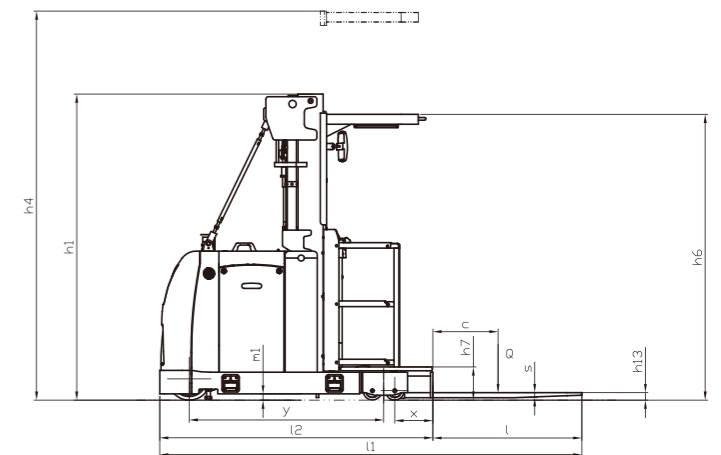
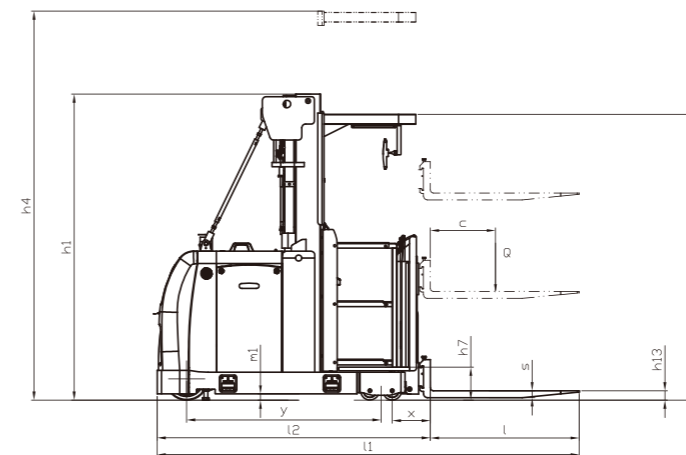

CJD12-AC1-H

CJD12-AC1-HK